

# On Site With Parallam

by Patricia Hamilton



A Parallam beam is heavier than an equivalent-strength steel I-beam. The author's crew lifts beams up to 16 feet by hand; beyond that, they use a crane.

**A**s builders of custom oceanfront homes, we use a lot of long structural beams. Whenever we build on pilings, as we often do, we use girders to transfer loads to the pilings. Also, increasingly, the architect-designed custom homes we build feature large open spaces and complex roofs that require heavy beams. Anytime the structure of a house requires something stronger, shallower, or longer than we can accomplish with three or fewer 2x12s, our beam of choice is Parallam.

I first used Parallam five years ago in a house that I designed and built for myself. The job went well and I was satisfied with how easily I could integrate Parallam into the frame. Not long after, I built a house where the architect specified that all the beams were to be multiple LVLs (Microllams) spiked together on site. After framing was finished, we noticed that the main girder in a flush-framed floor was sagging. The side-loading from the floor joists was causing the outside LVL in the laminated beam to separate from the other LVLs, putting too much load

on the one member. So we had to go back in and install through-bolts to pull the LVLs together. It wasn't a big deal, but from that time on I've requested that architects specify Parallam instead of LVL.

## Why Parallam

We like Parallams for many reasons. They are stronger, stiffer, straighter, and longer than nailed-up 2-by beams — with the added advantage that they don't have to be nailed up. On many of the homes I build, I'm able to set three or four main beams, each up to 40 feet long (not clear span), in place of 30 to 50 separate pieces of 2x12. This is a tremendous timesaver, although a crane or lift is a must for longer beams.

Strengthwise, Parallam beams are equivalent to multiple LVL beams, with the added benefit that you don't have to worry about laminating and side-loading issues or the expense of bolting. Also, we've often had to return LVL that is cupped or warped, whereas Parallams don't have these problems.

*For long spans and heavy loads, parallel-strand lumber beams are a good alternative to glulams and steel*



Unlike steel, Parallam integrates easily into a wood-frame structure, requiring only standard carpentry tools.



Parallam comes pressure-treated for exposed conditions. Recently treated beams may vary in size, but will eventually shrink back to the same dimension.

Compared with glulams, which have comparable strength, Parallam is somewhat more available in our market (see “Parallam vs. Glulam & Steel”). For an exposed beam, however, architectural-grade glulam is still the best option.

Parallam is more expensive than steel. Sometimes we use steel because of its greater strength, but Parallams are far simpler because they can be cut on site, drilled, and nailed with the tools found in every carpenter’s toolbox. In my experience, steel almost always involves tedious extra work to

integrate it into the wood frame. If a piece of steel is cut slightly too long, I have a problem; with Parallam, I get out a saw.

### Manufacturing and Availability

Parallam is the only available *paral-lam-strand lumber* on the market. It is manufactured by Trus Joist MacMillan (TJM, P.O. Box 60, Boise, ID 83707; 800/338-0515) at two plants — one in British Columbia and one in Georgia. The manufacturing process starts with strands of veneer cut from small second-growth trees. These strands are

aligned, coated with glue, then cured with a combination of pressure and microwave “cooking.” The patented process helps the glue bond with the individual fibers by heating the mass more evenly than is possible with radiant heat methods. The result is a very condensed wood-fiber beam that is stronger and stiffer than solid-sawn lumber.

Parallam is made in widths of 2<sup>11</sup>/<sub>16</sub>, 3<sup>1</sup>/<sub>2</sub>, 5<sup>1</sup>/<sub>4</sub>, and 7 inches and in depths to match the most common wood I-joists — 9<sup>1</sup>/<sub>2</sub>, 11<sup>7</sup>/<sub>8</sub>, 14, 16, and 18 inches. Parallam columns are also available, in a variety of sizes to accommodate standard wall framing — 3<sup>1</sup>/<sub>2</sub>x3<sup>1</sup>/<sub>2</sub>, 3<sup>1</sup>/<sub>2</sub>x5<sup>1</sup>/<sub>4</sub>, 3<sup>1</sup>/<sub>2</sub>x7, 5<sup>1</sup>/<sub>4</sub>x5<sup>1</sup>/<sub>4</sub>, 5<sup>1</sup>/<sub>4</sub>x7, and 7x7 inches. Both beams and columns are manufactured in lengths up to 66 feet, although in our area, lumberyard trucks can handle only up to 32 feet and we’ve never been able to get anything longer than 48 feet via flatbed.

Availability is not usually a problem: We can get most sizes in a week or less. Also, Parallams are essentially modular: Two 3<sup>1</sup>/<sub>2</sub>-inch-thick pieces can be nailed or bolted together to replace one 7-inch-thick piece. This can be a timesaver compared with waiting for a back-ordered size. TJM’s specifier’s guide gives schedules for nailing and bolting, depending on the load.

Although the glue used is waterproof, Parallams are intended for protected use. For outdoor use, CCA-pressure-treated Parallams are available (.4- and .6-lb. retention); we use these extensively in piling foundations.

## Parallam vs. Glulam & Steel

On a recent custom home, the author used Parallam for a grid of 18-foot clear-span beams. The chart shows how Parallam stacks up against equivalent-strength steel and glulam.

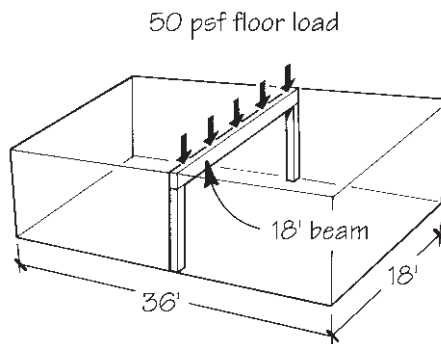

	Size	Weight (plf)	Cost
Parallam	7x14	30.6	\$389
Steel	W12x19	19	\$303
Glulam*	7 <sup>1</sup> / <sub>4</sub> x14	26.8	\$347

\*Southern pine 26F-V4, Industrial-grade

## Design and Planning

It's not uncommon for us to use 20 to 30 Parallam beams on a large (4,000 to 6,000 square feet) house. For these situations, we plan ahead and order early. For these situations, we plan ahead and order early. Usually we give our list to the yard and the beams arrive pre-cut. Because the lumberyard sells in 2-foot increments, we can often save money by having them cut two odd-length sizes from one longer piece.

Before ordering Parallams, we always check the engineer's drawings, looking for places where we can increase efficiency by ordering one longer beam instead of two shorter ones. For example, say the plans show a  $3\frac{1}{2} \times 11\frac{7}{8}$  beam and a  $5\frac{1}{4} \times 11\frac{7}{8}$  beam arranged in a straight line and ending on the same post. In this case, it's more cost-effective to increase the size of the smaller beam to  $5\frac{1}{4}$  inches and set one long continuous beam instead of two shorter simple-span beams. If the beams are in a 2x6 wall, then there's also less furring out to do.

When ordering Parallam, don't forget to order the steel connectors you'll need. The specifier's guide references Simpson connectors, but other manufacturers also make connectors sized for engineered lumber. Make sure the capacity of the hanger is adequate — you'll typically need to carry heavy concentrated loads.

Parallams are perfect for flush-framed floor beams. Single-member



For a ridge beam, the author saves time by using a single piece of Parallam rather than laminating a multiple-member LVL beam.



Steel connector manufacturers carry special hardware sizes to match the dimensions of engineered wood products like Parallam and I-joists. To avoid delays, be sure to order the connectors you need when you order the beams.

beams can be side-loaded with no problem; with laminated beams, make sure the nailing or bolting pattern is specified. Joist hangers typically do not need to be top-flange types, but make sure you install all the nails or bolts specified.

Beware of too many flush-framed floor beams, however: They can be a nightmare for your electrician, plumber, and hvac sub. Our rule on site, and the recommendation in the manufacturer's guide, is "no holes." In truth, within very strict criteria, a very few small holes are allowed, but too many flush-framed floors can greatly complicate electrical and mechanical installations.

If you're using the specifier's guide to make your own Parallam selection, be sure to allow enough bearing length for each end of the beam. The large loads carried by the beams will of course concentrate at the bearing points. Too little bearing surface area will result in crushed grain and the beam will settle.

## Handling and Installation

As with any lumber, it's possible to mistreat Parallam. If you leave an untreated Parallam in a mud puddle, it will turn gray, absorb water, and eventually show some signs of delamination. After the beams arrive on the job site, they should be protected from the weather and stored flat. After installation, Parallam will show normal signs of weathering. This is nothing to worry about, but if you notice any delamination of fibers, ask to have the manufacturer's rep inspect the beam.

We have noticed some size variation with CCA-treated Parallams, depending on how recently the beams came from the treatment tank. On a recent

job, some "14-inch" beams ranged in size from 14 to  $14\frac{1}{2}$  inches. TJM engineers assured us that in a few months the oversized beams would all shrink back to 14 inches. Within a week or so, the discrepancy had narrowed to about  $\frac{1}{8}$  inch, so we set all the beams even at the bottom, assuming continued shrinkage would fix the problem.

For very long lengths, you will need a crane or lift to unload and set the beams, although we have successfully handled lengths up to 16 feet with four men.

Cutting Parallam is about the same as with sawn lumber. Circular saws work fine, although you may need to cut from both sides and finish the cut with a handsaw. On jobs where we have to do a lot of cutting, we usually rent a 10-inch circular saw so we can cut most sizes in one pass. Drilling and nailing are no different than for solid lumber.

## Manufacturer Support

Technical assistance with the sizing of Parallams is readily available from the manufacturer. The specifier's guide is easy to understand and is adequate for most standard applications. If your plans have not been stamped by an engineer and you think there's a problem, you can get help directly from TJM's staff engineers. Call and explain your application or fax a plan, and they will advise on sizing, spans, connection hardware, drilling, and other details. Design software is also available, but generally is only needed by engineers, architects, and high-volume users. ■

Patricia Hamilton is owner of Boardwalk Builders in Rehoboth Beach, Del.